

# DIMENSION (KS B 1010 / JIS B1186)

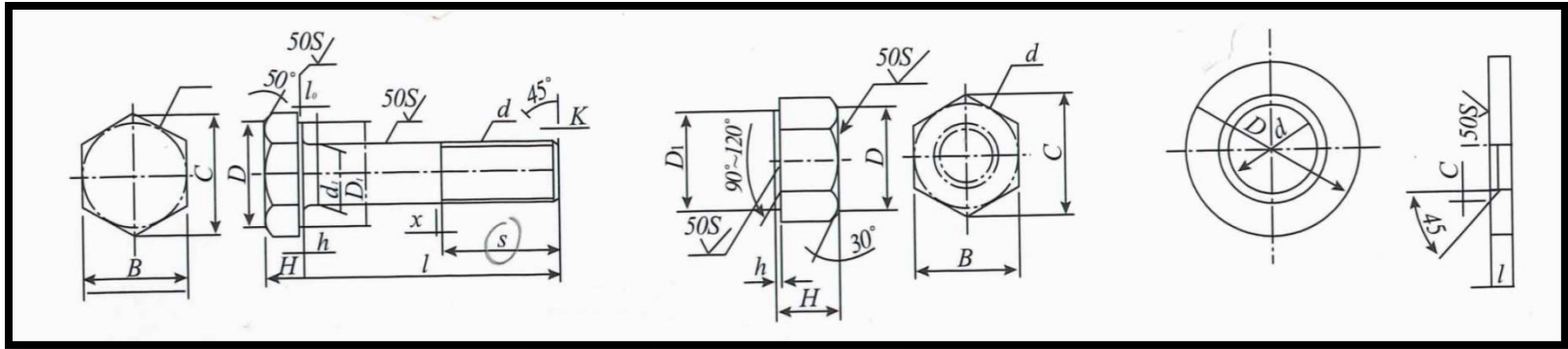

Nominal size of thread d X P	BOLT							NUT							WASHER				
	d1	H	B	C app.	D app.	D1 min.	r	h	S	H	B	C app.	D app.	D1 min.	h	d	D	t	c
M12 X 1.75	12	8	22	25.4	20	20	0.8-1.6	0.4-0.8	25	12	22	25.4	20	20	0.4-0.8	13	26	3.2	1.5
M16 X 2.0	16	10	27	31.2	25	25			30	16	27	31.2	25	25		17	32	4.5	
M20 X 2.5	20	13	32	37	30	29	1.2-2.0	0.4-0.8	35	20	32	37.0	30	29	0.4-0.8	21	40	6.0	2
M22 X 2.5	22	14	36	41.6	34	33			40	22	36	41.6	34	33		23	44		
M24 X 3.0	24	15	41	47.3	39	38	1.6-2.4	0.4-0.8	45	24	41	47.3	39	38	0.4-0.8	25	48	6.0	2.4
M27 X 3.0	27	17	46	53.1	44	43			50	27	46	53.1	44	43		28	56		
M30 X 3.5	30	19	50	57.7	48	47	2.0-2.8	0.4-0.8	55	30	50	57.7	48	47	0.4-0.8	31	60	8.0	2.8

Unit : mm