

DIMENSION (GB/T 3632)

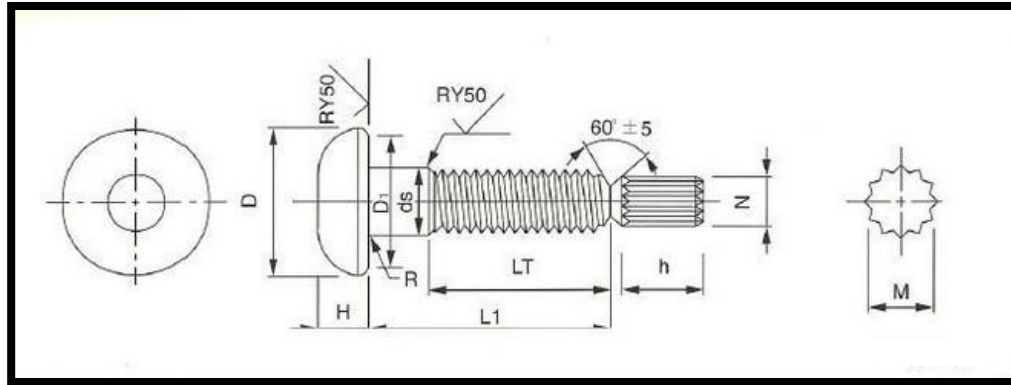

BOLT

DIAMETER	PITCH	D	D1	ds	H	LT	h	M
M16	2.00	30	27.9	15.57 - 16.43	9.25 - 10.75	L: 40-50 = 30mm; L: 55-130 = 35mm	12	11.0 - 11.3
M20	2.50	37	34.5	19.48 - 20.52	12.10 - 13.90	L: 45-60 = 35mm; L: 65-160 = 40mm	14	13.8 - 14.1
M22	2.50	41	38.5	21.48 - 22.52	13.10 - 14.90	L: 50-65 = 40mm; L: 70-180 = 45mm	15	15.3 - 15.6
M24	3.00	44	41.5	23.48 - 24.52	14.10 - 15.90	L: 55-70 = 45mm; L: 75-200 = 50mm	16	16.6 - 16.9
M27	3.00	50	42.8	26.16 - 27.84	16.10 - 17.90	L: 65-75 = 50mm; L: 80-220 = 55mm	17	18.7 - 19.3
M30	3.50	55	46.5	29.16 - 30.84	17.95 - 20.05	L: 75-80 = 55mm; L: 85-220 = 60mm	18	20.8 - 21.4

* UNIT : MM

DIMENSION (GB/T 3632)

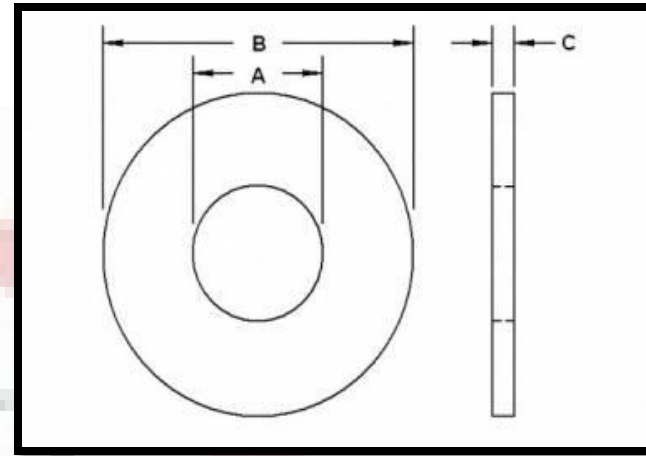
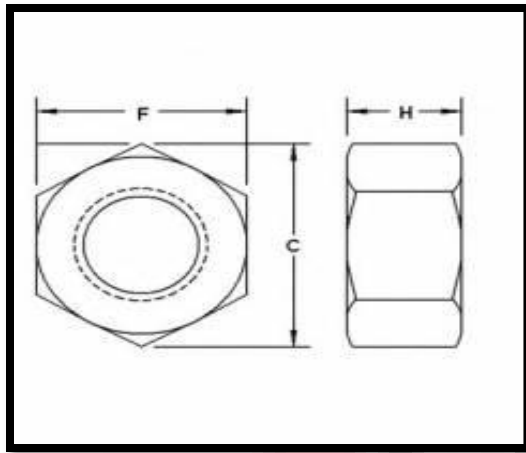

DIAMETER	NUT			WASHER		
	H	F	C	A	B	C
M16	16.4 - 17.1	26.16 - 27	29.56	17 - 17.43	31.4 - 33	3.5 - 4.8
M20	19.4 - 20.7	33 - 34	37.29	21 - 21.52	38.4 - 40	3.5 - 4.8
M22	22.3 - 23.6	35 - 36	39.56	23 - 23.52	40.4 - 42	4.5 - 5.8
M24	22.9 - 24.2	40 - 41	45.20	25 - 25.52	45.4 - 47	4.5 - 5.8
M27	26.3 - 27.6	45 - 46	50.85	28 - 28.52	50.1 - 52	4.5 - 5.8
M30	29.1 - 30.7	49 - 50	55.37	31 - 31.62	54.1 - 56	4.5 - 5.8

* UNIT : MM