

DIMENSION (JSS II 09)

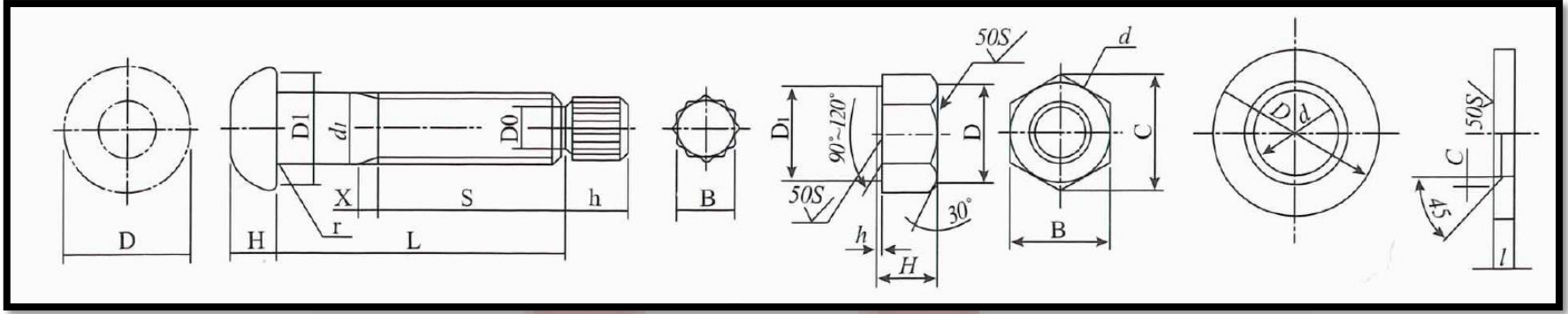

Nominal size of thread d X P	BOLT										NUT					WASHER				
	d1	D1 min	D min	H	do	h app.	B	r	a-b max.	S	H	B	C	D	D1	h	d	D	t	c
M16 X 2.0	16	26	27	31.2	N.M	15	11.3		0.8	30	16	27	31.2	25	25	0.4-0.8	17	32	4.5	1.5
M20 X 2.5	20	33	34	37		18	14.1		1.2-2.0	0.9	35	20	32	37.0	30		29	21		40
M22 X 2.5	22	37	38.5	41.6		19	15.4			1.1	40	22	26	41.6	34		33	23	44	6.0
M24 X 3.0	24	41	43	47.3		20	16.8	1.6-2.4	1.2	45	24	41	47.3	39	38		25	48		
M27 X 3.0	27	47	49	53.1		22	19		1.3	50	27	46	53.1	44	43		28	56		
M30 X 3.5	30	53	55	57.7		24	21.1	2.0-2.8	1.5	55	30	50	57.7	48	47		31	60	8.0	2.8

Unit : mm