

# DIMENSION (ISO 4032)

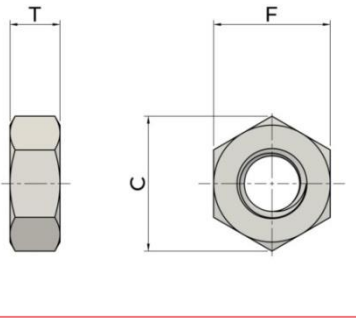

DIAMETER	AF (F), MM	AC [C], MM	THK (T), MM	
	MIN	MIN	REGULAR NUT (STYLE 1), MIN	HIGH NUT (STYLE 2), MIN
M6	9.78	11.05	4.90	5.40
M8	12.73	14.38	6.44	7.14
M10	15.73	17.77	8.04	8.94
M12	17.73	20.03	10.37	11.57
M14	20.67	23.35	12.10	13.40
M16	23.67	26.75	14.10	15.70
M18	26.16	29.56	15.10	16.90
M20	29.16	32.95	16.90	19.00
M22	33.00	37.29	18.10	20.50
M24	35.00	39.55	20.20	22.60
M27	40.00	45.20	22.50	25.40
M30	45.00	50.85	24.30	27.30
M33	49.00	55.37	27.40	30.90
M36	53.80	60.78	29.40	33.10
M39	58.80	66.44	31.80	35.90